

Product Puller System & Shelf Overlay

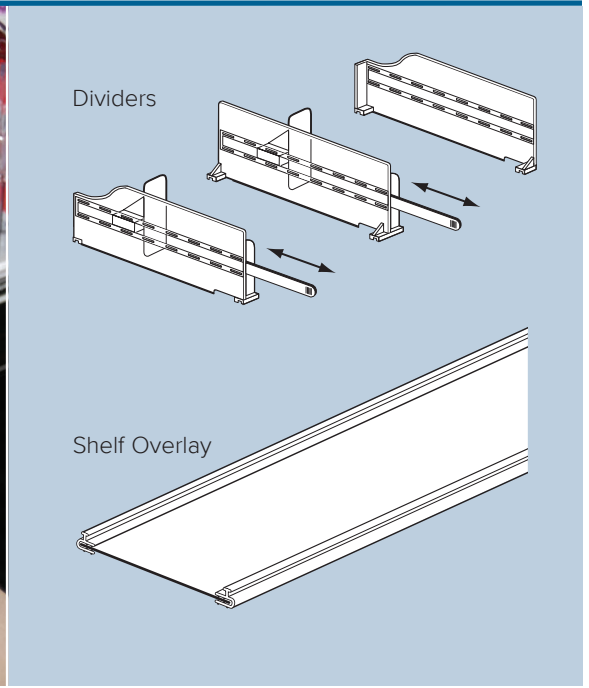

Features and Benefits

- ◆ Keeps products organized and accessible
- ◆ Increased sales due to section always looking full
- ◆ Clear dividers allow for full visibility of product
- ◆ Dividers adjust to any product width
- ◆ Puller System helps guarantee first-in, first-out rotation for product freshness
- ◆ Shelf Overlay with pebbled surface helps containers slide forward; available in 20" and 22" depths in black or white
- ◆ Tool-free assembly

Clear dividers adjust to any product width

Product Puller System & Shelf Overlay eliminates the hassles of stocking, stacking, and restocking for increased sales. Designed to fit any dairy case, its height efficient pull-out and pull tab features can increase labor savings as much as 50%.

New product can easily be placed behind existing shelf stock providing first in, first out rotation.

Specifications

Item No.	Ref. No.	Dimensions	Finish	Pack
Shelf Overlay				
9924018048	-	48" W x 20" D	White	1
9924013033	-	48" W x 20" D	Black	1
9924016273	-	48" W x 22" D	White	1
9924015176	-	48" W x 22" D	Black	1
Dividers				
9924015172	-	16 facing kit - 20" D x 4.375" H	Clear	1
9924016968	-	16 facing kit - 20" D x 7.25" H	Clear	1
9924013021	-	16 facing kit - 22" D x 4.375" H	Clear	1
9924011055	-	16 facing kit - 22" D x 7.25" H	Clear	1

Call for details. Minimum quantities may apply. Additional colors can be made to order.

20190313

For more information,
call **800.422.2547**
or visit www.siffron.com

siffron[™]
always on